

Machine for beveling pipe and tube edges

NKO MACHINES

Stinger 300



Instructions for use and maintenance



Content:

1. General information	3
2. Security	7
3. Technical specifications	9
4. Installation	13
5. Using	19
6. Accessories	26
7. Maintenance	27
8. Technical diagrams	28
9. Spare parts	29

1. General information

1.1. Introduction

Thank you for purchasing one of our machines and we hope you will be fully satisfied with it.

This manual contains all instructions for installation, adjustment, operation and maintenance of the machine

Stinger 300 in accordance with current safety standards.

The information and data in this manual may be subject to change as a result of further machine improvements. For the avoidance of doubt, please contact N.KO if you find any differences.

Never perform any operation on the machine before you have read and understood the instructions in the manual. A large proportion of accidents that occur in the workplace are caused by failure to follow the instructions and recommendations in the manual.

The graphic symbols in the manual are used to highlight important information regarding machine safety and operation.



Attention:

Essential information for the personal safety of the operator.



Important:

Instructions to be followed to ensure proper machine operation.

1.2. Tests

The edge shrinking machine is tested in our technical testing room.

During this test, the correct functioning of the machine is tested.

1.3. Warranty

The seller warrants the Stinger 300 beveling system to be free from defects in materials and workmanship for a period of 1 year from the date of delivery.

The faultless function of the goods and the materials used are guaranteed for a period of 1 year from the date of delivery.

The Seller undertakes to ensure that any defects covered by the warranty are rectified free of charge and without undue delay so that the Buyer can use the goods properly. If the Buyer exercises rights under liability for defects not covered by the warranty, the Buyer shall reimburse the Seller for the costs of doing so.

The warranty period does not run from the date on which the buyer has reported to the seller the existence of a defect covered by the warranty and for which the buyer cannot use the goods and has exercised his rights under liability for defects under the warranty provided, until the date of its removal by the seller.

The warranty does not cover natural and normal wear and tear of the goods and defects caused by improper use of the goods contrary to the training provided or the instructions for use. The warranty also does not cover defects caused by overloading of the machine and defects caused by unprofessional intervention in the machine or unprofessional repair or modification of the machine. Unprofessional tampering, repair or modification means any tampering, repair or modification which has been carried out in contravention of the training and documentation provided, or has been carried out by a person other than the Seller or a person authorised or approved by the Seller.

The rights of liability for defects under the warranty provided must be exercised with the seller without undue delay after the buyer discovers the defect, but no later than the end of the warranty period, otherwise these rights expire.

In order to exercise the rights of liability for defects under the warranty, the warranty certificate or proof of purchase must be presented. Otherwise, the buyer cannot be granted these rights.

The Seller shall not be liable for defects covered by the warranty if these defects are caused by external events. External events include, in particular, natural disasters, acts of God or the behaviour of third parties.

N.KO considers the guarantee void if:

- improper use of the machine
- use contrary to national or international standards
- incorrect installation of the machine
- faulty power supply
- serious deficiencies and maintenance errors
- unauthorised modifications or interference
- use of non-original or incorrect spare parts and accessories for the model in question
- complete or partial non-compliance with the instructions in the manual
- exceptional events, natural calamities, or other.

1.3 Identification data

The identification data of the bevel bevelling machine is shown on the aluminium CE label attached to the machine body.

1.4 Reference standards (CE declaration of conformity)

EC Declaration of Conformity

pursuant to Section 13(2) of Act No. 22/1997 Coll., as amended

We,
N.KO spol. s r.o.
Táborská 398/22, 29301 Mladá Boleslav, ICO: 26161109

Product - trade name:
We declare under our sole responsibility that
Stinger 300 bevelling system

Type:
Stinger 300

is primarily intended for the bevelling and deburring of the parts to which this declaration applies, is under conditions of normal use is safe and complies with the following technical regulations:

Standards
CSN EN 60204-1 ed. 3:19, CSN EN ISO 12100:11, CSN EN 31010:11, SN EN ISO 14120:01/17 +01:08/17, CSN EN ISO 16090-1:19, CSN EN 50370-1:05, CSN EN 50370-2:03 all as amended

NV 176/2008 Sb. As amended	2006/42/EU including amendments
NV 117/2016 Sb.	2014/30/EU including amendments
NV 481/2012 Sb. As amended	2011/65/EU including amendments

And these government regulations, as amended (NV) and EU directive numbers:

Person in charge of completing the technical documentation:

The machinery complies with all relevant provisions of Directive 2006/42/EC, as amended.

The machinery complies with all relevant provisions of Directives 2014/30/EU, 2014/35/EU and 2011/65/EU, all as amended.

Conformity assessment was carried out in accordance with the procedure according to § 12, paragraph 3 letter a) of the Act 22/1997 Coll., as amended.

Issued in Ml. Boleslav on
25. 5. 2023

CEO - Milan Richtř

N.KO spol. s r.o.
Táborská 398, 293 01 Mladá Boleslav
ICO: 26161109 DIČ: CZ26161109
Tel: +420 32577201 Fax: +420 325774779
www.nko.cz www.bevcler.cz

2. SAFETY

2.1 Safety recommendations



Attention:

Please read the following instructions thoroughly to prevent personal injury or damage to property.

- Never attempt to operate the machine until you have thoroughly familiarised yourself with the way it works. If you are still in doubt after carefully and completely reading this manual, contact N.KO.
- Ensure that all technicians who are to use and maintain the machine are sufficiently familiar with all relevant safety recommendations.
- The machine must only be transported and installed by designated personnel in accordance with the instructions in this manual.
- Before starting the machine, the operator must make sure that all safety devices are functional and that all safety guards are fitted.
- Never use the machine for purposes other than those listed in the manual. Never process products or workpieces other than those specified.
- Please contact N.KO before using the machine for any purpose other than those listed above to request permission.
- The voltage values used to power the machine are dangerous: make sure all connections are made correctly. Never carry out maintenance on the machine or replace parts when the machine is connected to a power source and never make any taps on electrical connections.
- Replace parts considered defective with others recommended by the manufacturer. Never replace with non-original spare parts.
- Never wear clothing or jewelry that could get caught in moving parts. It is advisable to wear safety clothing: shoes with non-slip soles, ear defenders and safety glasses.



Important:

If during the lifetime of the machine any faults arise that cannot be repaired according to this manual, you must contact your supplier or the manufacturer, N.KO, to resolve the problem as soon as possible.

2.2. Safety stickers

Safety stickers are applied to the bevel beveling machine to protect the operator.

Meanings of stickers:

This sticker is applied to the electrical panel of the bevel beveling machine to indicate the presence of high voltage.



Do not remove this sticker from the machine

2.3 Operator qualification and protection

The employer is obliged to inform the operator of the safety standards and, in addition, to ensure that they are complied with and to make sure that the work area is large enough and well lit. The machine may only be operated and operated by a designated person, the machine operator.

The term 'operator' means the person who installs, operates, adjusts, maintains, cleans and repairs the machine. This person must be fully familiar with this manual and trained by the supplier. If this is not the case, ask your supplier to correct it. Otherwise, the manufacturer disclaims any liability for damages or injuries incurred.



Attention:

Before starting work, make sure that the operator has read and understood the contents of these operating instructions.



Attention:

The operator must always:

- Ensure that all safety guards are fitted and that safety devices are operational before starting the machine.
- Avoid wearing the type of clothing or jewelry that could get caught in the moving parts.
- Wear approved safety clothing, such as shoes with non-slip soles, ear defenders and safety glasses.
- Apply safety standards, ensure that they are always followed and refer back to this manual if in doubt.
- Contact the machine supplier when the faults that cause the machine to malfunction cannot be rectified, when the faults relate to malfunctioning parts or irregular operation.

2.4 Safety equipment

The machine is equipped with a safety protection frame. This frame partially encloses the area where the tool holders rotate.



Attention:

Never operate the machine without the protective frame fitted.

2.5 Remaining risks

The machine is partially fitted with covers to reduce the risk of contact with moving parts were excluded as much as possible.

But there is one remaining risk:

As mentioned above, the work zone is protected as much as possible, but must remain partially open in order to monitor the machining process.

It is therefore possible that the operator could insert his fingers into this zone, where both the cutting tool and the workpiece holder are located.



Attention:

Always keep your hands and other body parts as far away from the cutting zone as possible.



Attention:

Always apply the safety regulations in the manual and ensure that they are followed and that any remaining risks are eliminated.

3. TECHNICAL SPECIFICATIONS

3.1. Machine description

The Stinger 300 is a pipe and tube edging machine developed for beveling and aligning pipes and tubes made of structural and stainless steel.

One of its main features is that it is portable and can perform up to three cutting operations simultaneously. These are, pipe alignment, beveling of edges and internal recessing (calibration), alignment of internal diameters of pipes and tubes.

The machine is equipped with a powerful motor, a robust clamping mandrel and two cutting tool holders.

The Stinger 300 can be used directly on the pipes to be machined or mounted in a stand (accessory) as a stationary device for machining shorter pipes, tubes.

The Stinger 300 machine consists of the Stinger 300 itself, the drive unit, clamping mandrels and accessories.

The Stinger 300 bevel edger is reliable and requires only minimal maintenance.

Fig. 3.1.1.

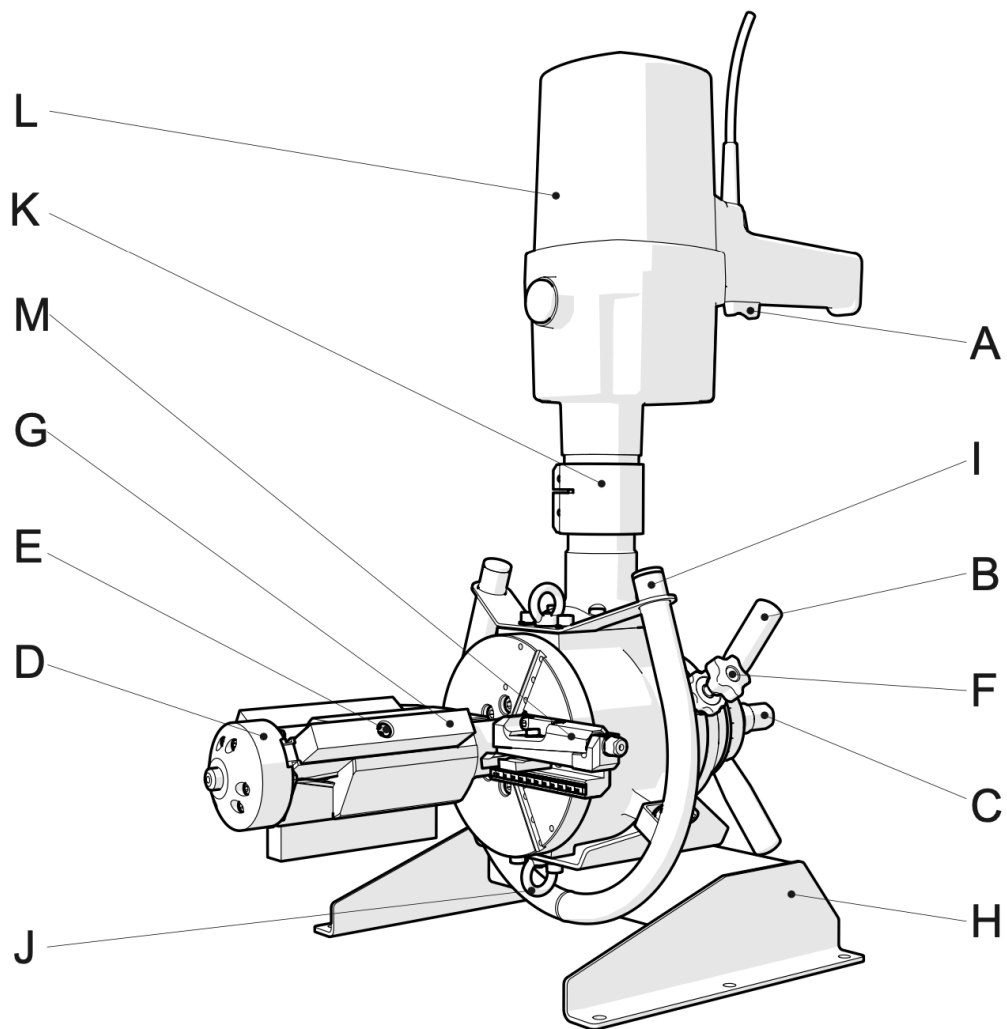

- A. Main switch
- B. Machine cutting control rod
- C. Machine clamping screw
- D. Clamping mandrel (version A or B)
- E. Clamping jaw screw
- F. Bearing centring bolt
- G. Compensating clamping jaws
- H. Additional stand (optional accessory)
- I. Protective frame
- J. Hanging transport eye
- K. Connecting sleeve
- L. Power plant Stinger 300
- M. Cutting tool holder

3.2 Technical data

The Stinger 300 consists of the motor, the Stinger 300 itself, the clamping mandrel used and, if necessary, an additional stand

Power unit / engine:

Voltage	230 or 120V (single phase)*
Frequency	50/60 Hz*
Motor power input	1800W (2-speed gearbox + electric speed control)

Engine speed:

Speed #1.	60 - 140 rpm
Speed No.2.	200 - 470 rpm
Motor clamping	MK3 + adapter for Stinger 300
Overload protection:	Mechanical and electronic - thermal

Stinger 300:

Max. machinable pipe wall thickness	15 mm (0.59")
Max bevel size (bevel width) (steel Rm < 400Mpa)	20 mm.(0.78"). Always depends on the angle or shape of the bevel.
Range of bevel angles	Depends on the tool used (standard 0°/15°/30°/37.5°)
Feed to cut/lift	Handheld/60 mm (2.36")

Clamping mandrels and clamping range:

Mandrel A.	ID 36 - OD 86 mm (1.41" - 3.38") accessories on request
Mandrel B.	ID 86 - OD 269 mm (3.38" - 10.59") Included

Weight:

Stinger 300 + motor + A mandrel	31 kg (68 lb)
Stinger 300 + motor + B mandrel	36.6 kg (80.6 lb)
Additional stand	5.8 kg (12.7 lb)

(*) Specific voltage and frequency values are indicated on the machine's motor identification plate.

3.3. Noise level

The machine has been designed and manufactured to keep the noise it makes to a minimum. Measurements taken from the operator's position, with the machine running in automatic cycle mode, produced the following values:

- during cutting **74.9 dB**
- during no-load operation **64.5 dB**

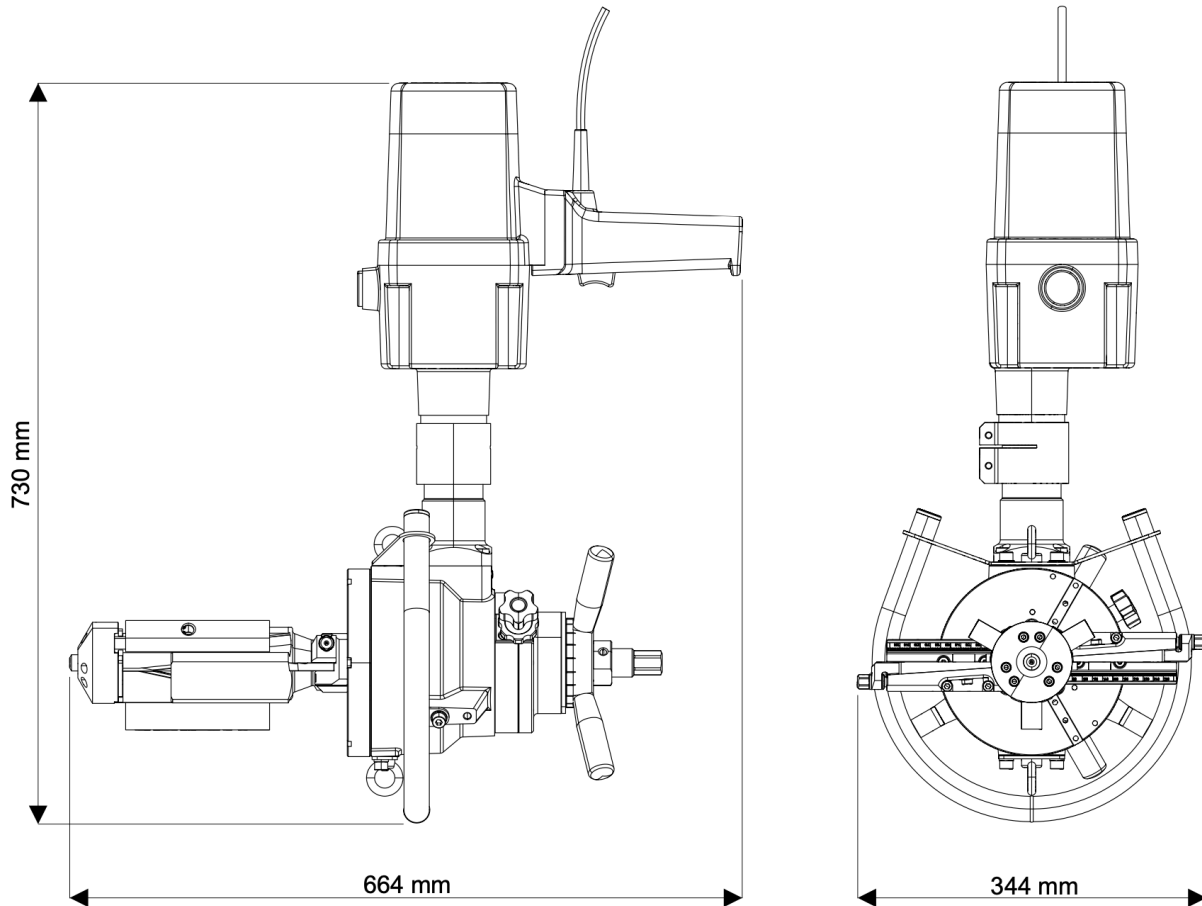

3.4 Working environment conditions

The environment in which the machine operates must comply with these values:

- Temperature: 0° C - 50° C (32° F - 122° F)
Humidity: 10% - 90% (non-condensed)

The machine must be placed in a sheltered location and must not be exposed to rain.

Working environment conditions other than those mentioned above could cause serious damage to the machine or injury (especially electric shock).

When the machine is not working, it can be stored in a place where the temperature fluctuates between:

- 10° C and 70° C (14° F - 158° F)
all other values remain unchanged.

4. INSTALLATION

4.1 Transport and lifting



Important:

The activities described in this section must only be carried out by qualified personnel.

When the machine is delivered to its destination, make sure (in the presence of the transport company) that it matches the specifications in the order and that it has not suffered any damage during transport. Immediately inform the supplier and the transport company in detail if damage is found or if parts are missing.



Attention:

Follow the following instructions to ensure that the machine is safe to handle:

- You can manipulate the Stinger by hand or use cranes or other lifting equipment. Use the installed suspension lugs or the machine's protective frame for hanging (Fig. 4.1.1.).
- Keep clear of hanging loads and ensure that the lifting equipment and associated tools are in good order and suitable for the equipment weights specified in paragraph 3.2.
- Wear protective clothing such as work gloves, non-slip soled shoes and a helmet when handling and using the machine.
- If you dispose of additional transport packaging, dispose of it in accordance with the applicable waste disposal laws of the country concerned.

Fig. 4.1.1.

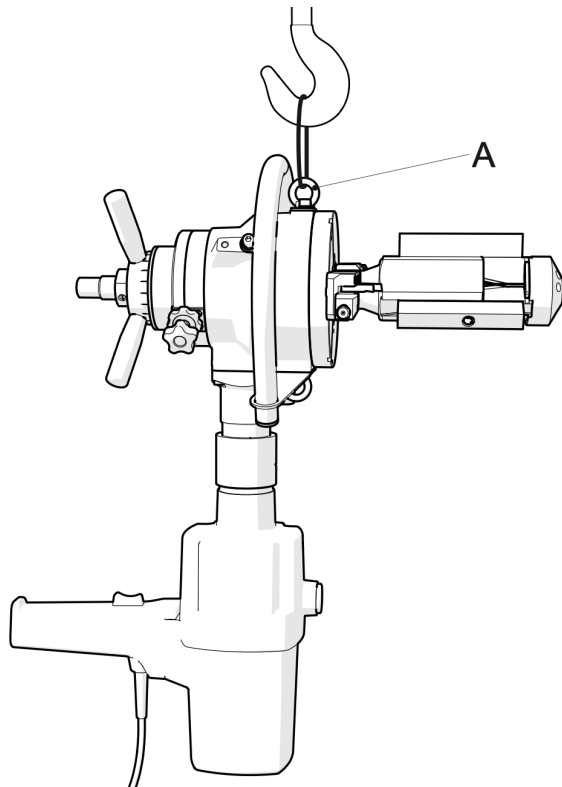

4.2 Setup and connection



Important:

The activities described in this paragraph must only be carried out by qualified personnel.

When making electrical connections, proceed as follows:

- check the frequency and voltage values on the motor identification plate and compare them with the mains electricity supply at the place where you use the machine.

4.3 Setting up the Stinger 300 and checks before use



Important:

Never start the Stinger 300 without performing the procedures described in this paragraph.

As mentioned above, the Stinger machine consists of multiple components and must be pre-assembled and prepared for a specific application.

Stinger 300 + power unit

First, the Stinger 300 itself must be assembled. This is done by attaching the motor to the body of the Stinger 300. Follow the schematic diagram (Fig. 4.3.1.)

- Install the coupling sleeve (pos. B Fig. 4.3.1.) on the connection neck of the drive unit (pos. C Fig. 4.3.1.).
- Install the drive unit (pos. A fig. 4.3.1.) into the prepared socket, according to the schematic picture. Make sure that the drive shaft connecting square is correctly seated in the hole in the shaft of the Stinger 300 unit.
- Tighten the screws on the coupling sleeve properly.

Fig. 4.3.1.

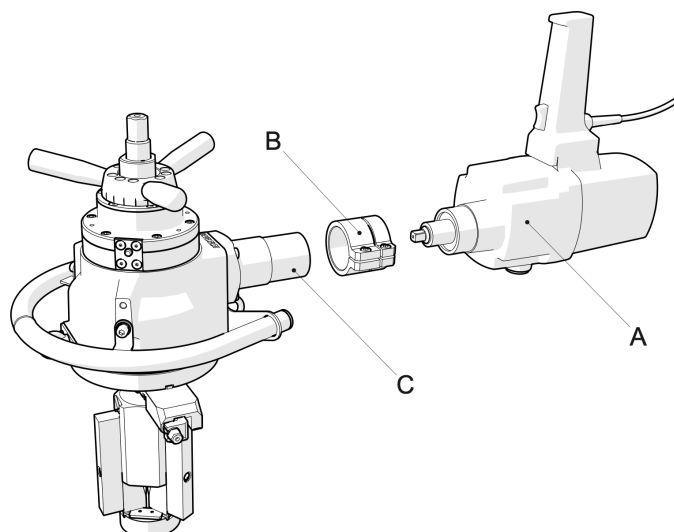

Clamping mandrel, its preparation and assembly

Now it is necessary to install the correct clamping mandrel, type A or B. (Fig. 4.3.2.) The type of mandrel depends on the diameter of the pipe to be machined. Mandrel A is standard on the Stinger 300. Mandrel B can be purchased as an accessory. The exact clamping ranges of the individual mandrels can be checked in article 3.2 Technical data.

Fig. 4.3.2.

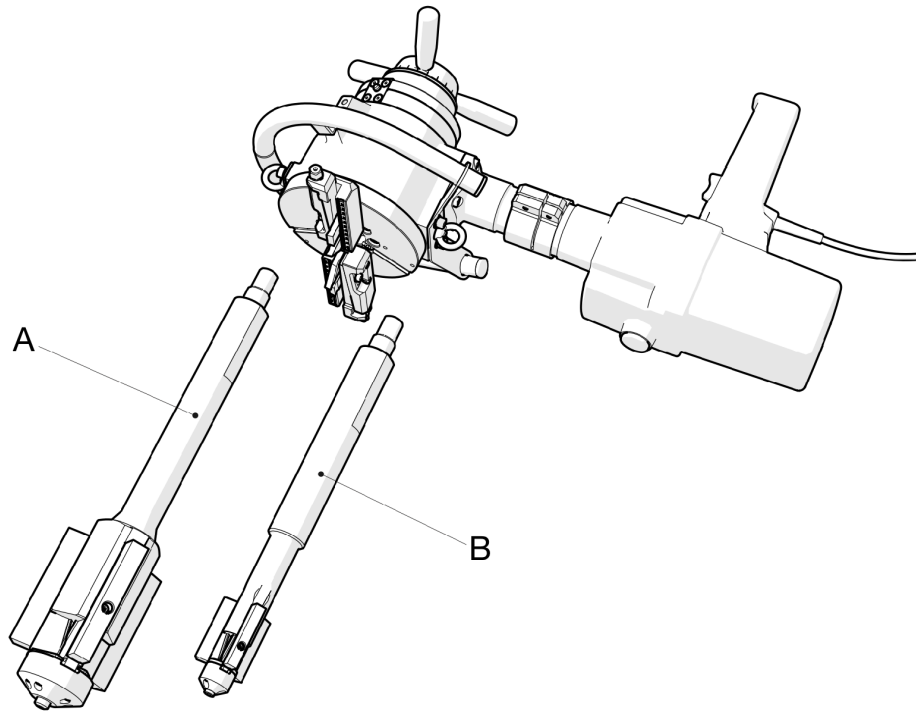

- Insert the mandrel (pos. B fig. 4.3.3.) into the hole in the tool plate (pos. A fig. 4.3.3.) and slide it until the outer thread of the mandrel hits the inner nut of the machine feed.
- Slowly turn the feed rose (pos. B Fig. 3.1.1.) and gradually screw the arbor into the machine. Be careful not to damage the mandrel thread or the feed nut of the machine.
- Unscrew the arbor to the desired position.

Fig. 4.3.3.

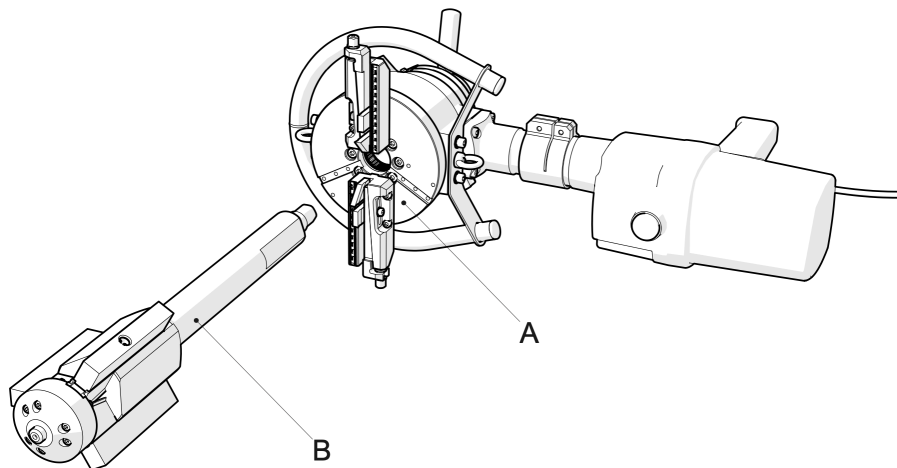

Compensating jaws - correct selection and installation

- Prepare the correct compensating jaws (pos. B fig. 4.3.4.) according to the exact inner diameter of the pipe to be machined. Use the table below to select the correct compensation jaws. For some pipe/pipe diameters it may be necessary to select a combination of compensating jaws and Booster jaws (pos. C fig. 4.3.4.) .
- You will always need three sets of identical jaws per fitting.
- Tighten the compensation jaws (pos. B Fig. 4.3.4.) on the clamping mandrel (pos. A Fig. 4.3.4.) properly using the built-in screws.

Mandrel B (clamping range 36-82 mm / 1.41"-3.22")

Required pipe diameter	Compensation jaw assembly
36 - 44 mm (1.41" - 1.73")	Base mandrel A without compensating jaw
44 - 53 mm (1.73" - 2.08")	Base mandrel A + A-1
53 - 62 mm (2.08" - 2.44")	Base mandrel A + A-2
62 - 71 mm (2.44" - 2.79")	Base mandrel A + A-3
71 - 80 mm (2.79" - 3.14")	Base mandrel A + A-4

Mandrel A (clamping range 82-269 mm / 3.22"-10.59")

Required pipe diameter	Compensation jaw assembly
82 - 100 mm (3.22" - 3.93")	Base mandrel B without compensating jaw
98 - 118 mm (3.85" - 4.64")	Base mandrel B+B-1
115 - 132 mm (4.52" - 5.19")	Base mandrel B+B-2
131 - 154 mm (5.15" - 6.06")	Base mandrel B+B-3
145 - 162 mm (5.70" - 6.37")	Base mandrel B+B-4
158 - 176 mm (6.22" - 6.92")	Base mandrel B+B-5
173 - 192 mm (6.81" - 7.55")	Base mandrel B+B-6
175 - 195 mm (6.88" - 7.67")	Basic mandrel B + B-1 + booster
192 - 209 mm (7.55" - 8.22")	Basic mandrel B + B-2 + booster
208 - 231 mm (8.18" - 9.09")	Basic mandrel B + B-3 + booster
222 - 239 mm (8.74" - 9.40")	Basic mandrel B + B-4 + booster
235 - 253 mm (9.25" - 9.96")	Basic mandrel B + B-5 + booster
250 - 269 mm (9.84" -)	Basic mandrel B + B-6 + booster

Fig. 4.3.4.

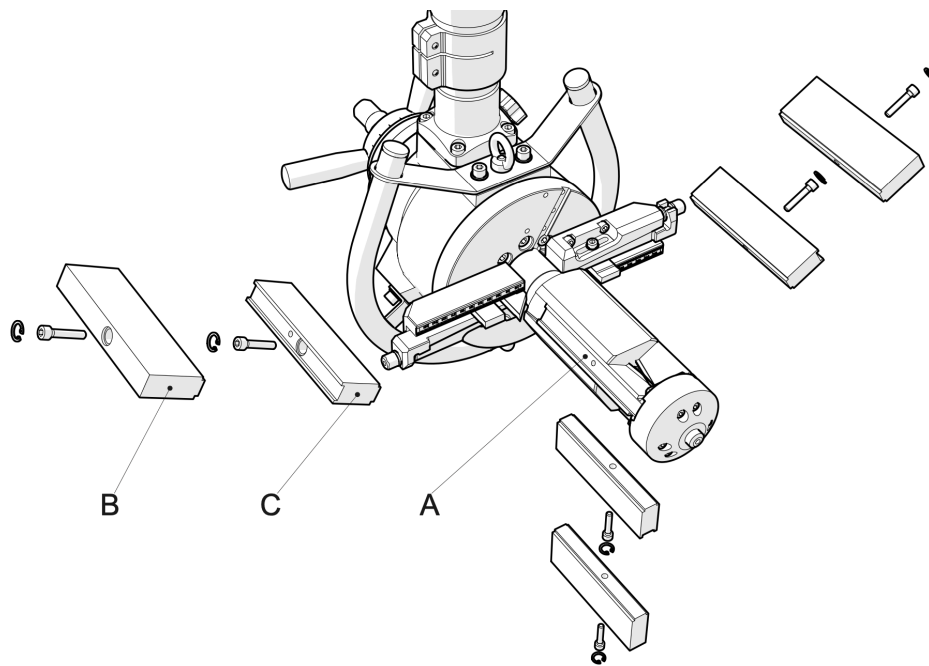

Cutting tool holders

The Stinger 300 is equipped with two cutting tool holders as standard (pos. M fig. 3.1.1.). These holders are installed on the tool plate, facing each other at an angle of 180° (pos. A Fig. 4.3.5.). In this way they can perform two machining operations at the same time. For example, beveling and alignment of the pipe/tube face. The holders are installed from the factory.

If required, a third bracket can be installed, which can be purchased as an accessory. In this case, the brackets are mounted in a 120° configuration (pos. B Fig. 4.3.5.). The tool plate has the appropriate mounting slots for two or three brackets already prepared from the factory.

Installation of the holders is therefore very intuitive, using the grooves and the screws provided.

Fig. 4.3.5.

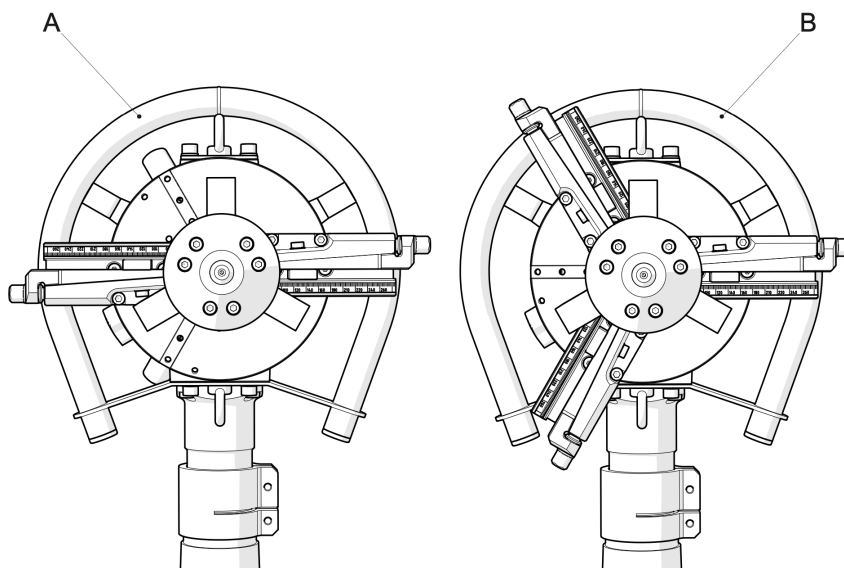

Final check before first use of the machine

- make sure that no screws or other parts are loose.
- make sure that the electrical supply cable is intact throughout its length and fitted with the correct connector.

4.4 Destruction and disposal

When destroying the Stinger 300, keep in mind that the materials from which it is made are not of a hazardous nature and that they include barrels:

- Lacquered or plated ferritic steel
- Stainless steel 300/400 series
- Plastic material of different nature
- Lubricants
- Electric motor
- Electrical cables and wires
- Electrical monitoring and wake-up devices.

Follow this procedure:

- Follow the applicable laws in your country relating to occupational safety and waste disposal
- Disconnect the machine from the power supply
- Dismantle the machine and sort the components into groups according to their chemical nature and composition
- Scrap machine parts in accordance with your country's waste disposal laws
- Strictly observe the applicable occupational safety regulations during the dismantling phases.

5. USING

5.1 Correct use

The Stinger 300 bevel edge beveling machine was designed, manufactured and sold for the purpose of preparing welding surfaces (beveling) of metal parts and rolled metals of the following types:

iron, steel, stainless steel, brass, copper and aluminium.

The maximum pipe dimensions and wall thicknesses of machined pipes are detailed in chapter 3, paragraph 3.2 Technical data.

Uses other than those described above are considered inappropriate. More specifically, it is prohibited:

- To process products different from those for which the machine is manufactured and sold.
- Modify the design and operation of the machine.
- Replacing parts with non-original ones.
- Modify electrical connections to bypass internal safety devices.
- Remove or modify protective covers.
- Do not use the machine in places where the environment is aggressive and where there is a risk of sticking parts.

The Stinger 300 can be used in two ways:

- Stationary, For machining short tubes. In this mode, the Stinger 300 is clamped in an additional stand, which can be purchased as an accessory (pos. H Fig. 3.1.1.).
- On long pipes, or on existing pipes where the Stinger 300 is clamped directly into the pipe being machined.



Attention:

It is strictly forbidden to carry out bevel beveling on materials other than those specified, as their processing could become a hazard to the operator and damage the machine.

N.KO must be contacted for approval before any modifications are made. Otherwise, N.KO disclaims any liability for damage to the machine or injury to the operator.

5.2 Description of drive controls

The Stinger 300 bevel edger is operated by means of controls located on the drive body (pos. L fig. 3.1.1.)

- (pos. A fig. 5.2.1.) Start button on the drive handle to switch on the machine
- (pos. D Fig. 5.2.1.) Rotary control for machine speed adjustment (adjust as required).
- (pos. C fig. 5.2.1.) Slide control for two-speed mechanical gearbox (we recommend always setting the stronger gear No.1).
- (pos. B Fig. 5.2.1.) Rotary control for setting the machine power (always set the maximum).

Fig. 5.2.1.

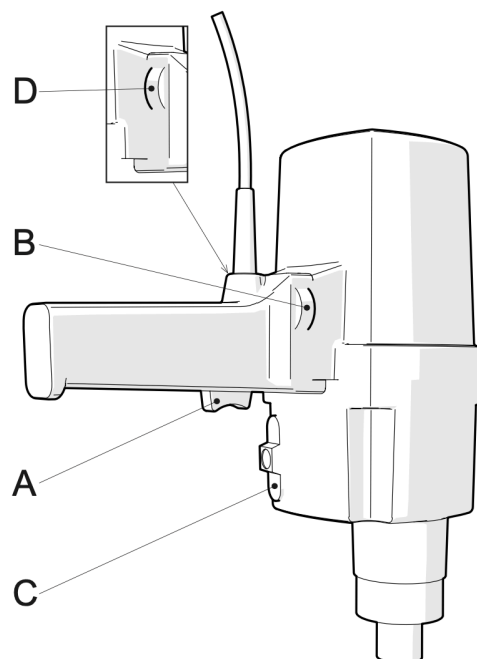

5.3 Preliminary settings



Attention:

Wear work gloves when adjusting. Operations must be carried out on the machine at rest and after disconnecting it from the power supply.

Installation of the Stinger 300 on the pipe to be machined.



WARNING Work with maximum concentration. The machine is quite heavy and there is a risk of injury. If desired, use a crane.

- The working stroke of the tool is approximately 60 mm. Therefore, before mounting the Stinger 300 in the pipe to be machined, it is necessary to adjust the clamping mandrel extension so that, once installed and clamped inside the pipe to be machined, sufficient space is left for the required working stroke of the tool. So that the intended size of machining can be carried out. The extension is adjusted by turning the machine's cutting control rosette (pos. B fig. 3.1.1.).
- The opening of the jaws of the clamping mandrel must be set so that the mandrel with the jaws can be freely inserted into the pipe to be machined. Ideally set the jaw spread diameter 5mm less than the inside diameter of the pipe to be machined. Adjustment is made by turning the machine clamping screw (pos. A fig. 5.3.2.).
- Now insert the entire prepared machine into the machined pipe and centre the Stinger 300 in the axis of the machined pipe using the machine clamping screw (pos. A Fig. 5.3.2.) and secure it by tightening the machine clamping screw (pos. A Fig. 5.3.2.).

Fig. 5.3.1.

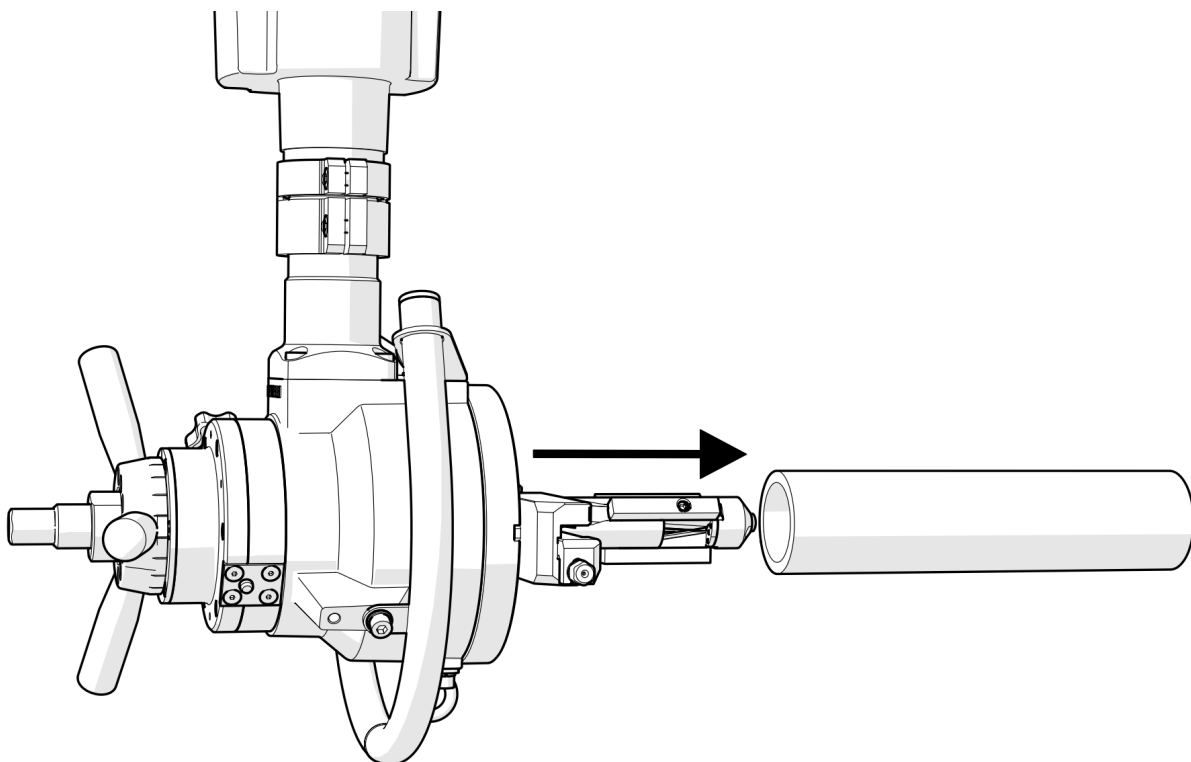
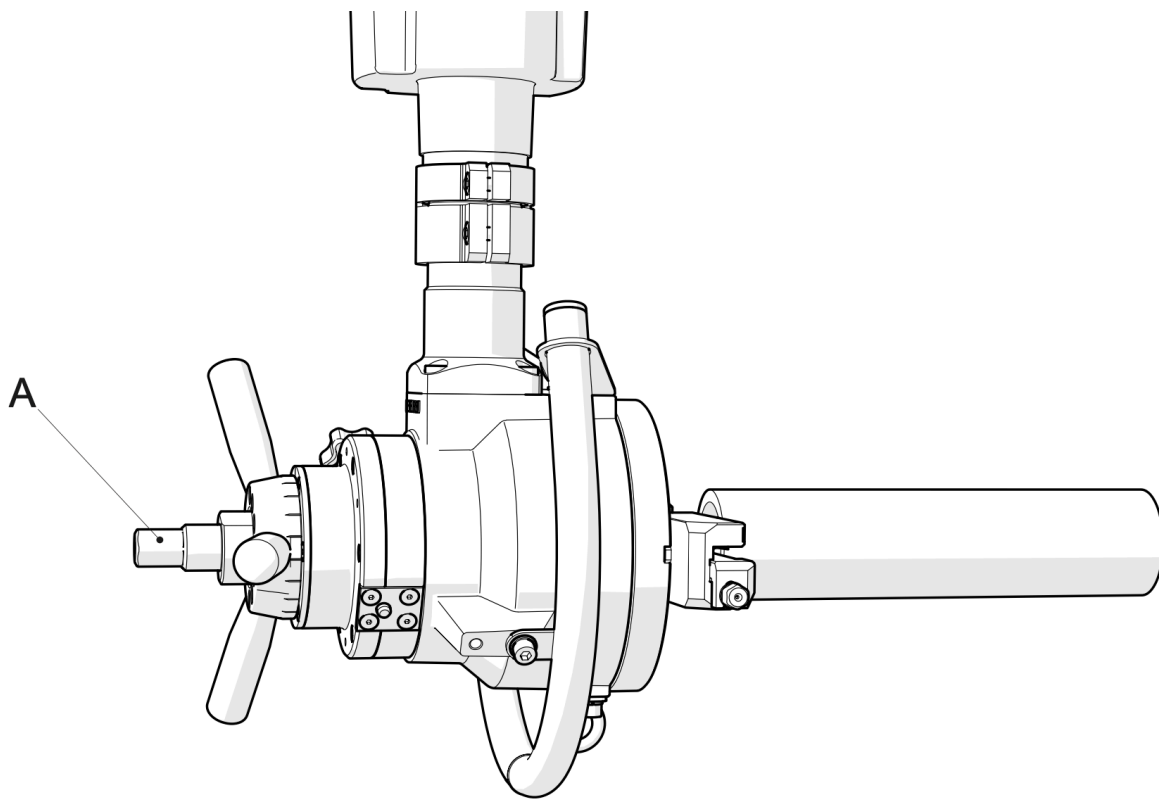

Fig. 5.3.2.



⚠ ATTENTION To increase safety and ease of handling, it is recommended to install the machine on the pipe to be machined in two steps. First install the machine tool itself (pos. C fig. 4.3.1.) and then connect the drive (pos. A fig. 4.3.1.). Follow chapter 4.3 *Setting up the Stinger 300 and checks before use*. This procedure will not lift the full weight of the machine.

● Important: Install the machine with the drive in the upward position. The drive is thus better protected against flying chips and residues of used cooling emulsion or other cutting oil.

Installation and adjustment of cutting tools

The clamped and centred Stinger machine must be fitted with cutting tools according to the operation to be performed. This means chamfering, face alignment or internal countersinking and calibration.

● Important: Be aware that if you wish to perform all of the above operations at the same time, you will need to purchase and install an extra 3rd tool holder. See section 4.3 - *Cutting tool holders*.

Proceed as follows:

- Clamp the required cutting tool in the tool holder so that its cutting edge is in the same position as the machined edge of the pipe wall. The gauges installed on the knife holder can help you.
- Tighten the carefully seated cutting tool in the jaw of the tool holder, using the screw (pos. A Fig. 5.3.3.)
- Do the same for the second or third tool holder.
- For more information on the correct machining procedure, see chapter 5.4 Machining.

Fig. 5.3.3.

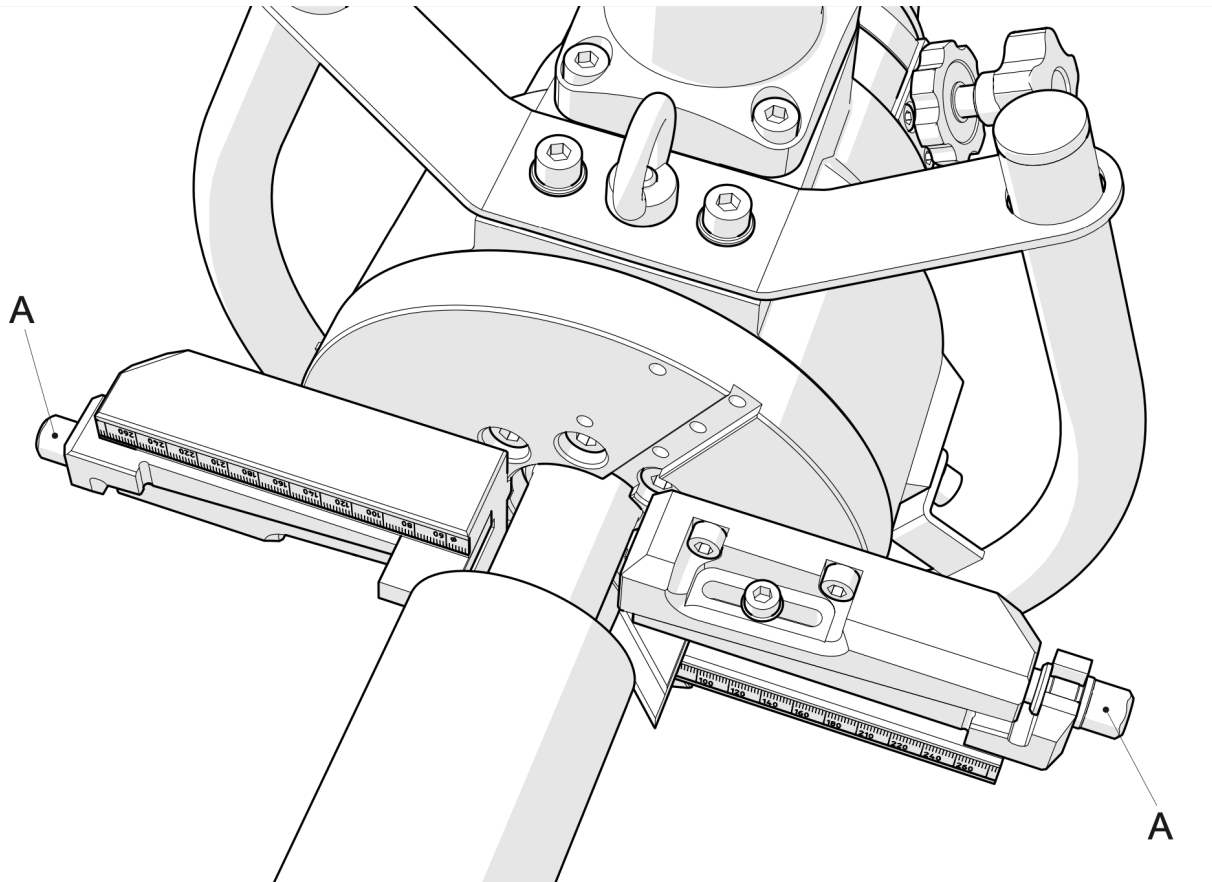

5.4 Machining



Important:

The operations described in this chapter must only be carried out after the Stinger 300 has been set up and prepared according to the previous chapters.

As already mentioned, the Stinger can perform up to three operations at the same time. These are edge alignment, beveling and internal countersinking - calibrating the inner diameter of the pipe.

Alignment of the pipe face

Use the 0° cutting tool.

- Install the 0° cutting tool into any tool holder (pos. M fig. 3.1.1.) for the alignment of the face.
- Switch on the machine and use the speed control (position D Fig. 5.2.1.) to select the appropriate speed for the material to be machined. It always depends on the operator's feeling and other circumstances (material strength, cutting tool condition, etc.).
- Turn the cutting control rosette (pos. B Fig. 3.1.1.) to move the cutting tool to the edge to be cut.
- If the edge of the pipe is not square, the cutting tool will only touch the edge of the machined pipe in some places. By successive machining, you then achieve a situation in which the cutting tool works around the entire circumference of the pipe edge. At this point the machining is complete and the edge of the pipe is aligned.
- If the pipe needs to be shortened further, continue machining until the pipe is at the desired machining level.
- It is recommended to use two alignment knives in the holders installed opposite each other for the operation of aligning the pipe face, see chapter 4.3. article *Cutting tool holders*. The load on the machine and drive is thus more even, eliminating the risk of one-sided overloading of the machine.

Creating a bevel

Use the cutting tool according to the desired bevel angle of 30° or 37.5°.

(Or a custom tool).

- Install the cutting tool of the desired shrink angle into any tool holder (pos. M Fig. 3.1.1.).
- Switch on the machine and use the speed control (position D Fig. 5.2.1.) to select the appropriate speed for the material to be machined. It always depends on the operator's feeling and other circumstances (material strength, cutting tool condition, etc.).
- Turn the cutting control rosette (pos. B Fig. 3.1.1.) to move the cutting tool to the edge to be cut.
- If the edge of the pipe is not square, the cutting tool will only touch the edge of the machined pipe in some places. By successive machining, you then achieve a situation in which the cutting tool works around the entire circumference of the pipe edge. Continue in this way until the complete edge of the tube is machined.
- It is recommended to use two beveling knives in holders installed opposite each other for the beveling operation, see chapter 4.3. article *Cutting tool holders*. The load on the machine and drive is thus more even, eliminating the risk of one-sided overloading of the machine.

The bevel is machined without the so-called blunting (root). This means that the bevel is made to the very edge of the pipe (to the barb). If you want to leave a part of the pipe edge without the bevel, i.e. with a blunt, proceed as follows:

- Turn the cutting control rosette of the machine (pos. B Fig. 3.1.1.) to move the cutting tool slightly away from the edge to be cut.
- Remove the beveling knife or slide it slightly outwards from the pipe, within the tool holder itself (pos. M Fig. 3.1.1.).
- Install the alignment knife 0° in the second tool holder (pos. M Fig. 3.1.1.) and work the desired bluntness.
- This completes the bevel. If at this point you bring the beveling knife in again, close to the machined edge, i.e. into the cut, the Stinger 300 will be adjusted for repetitive operation. Each subsequent bevel will be machined with the same parameters.
- Now you can just loosen the mandrel clamping slightly with the screw (pos. A fig. 5.3.2.), remove the machine from the machined pipe and clamp it in another pipe of the same size, where you can make (without any further adjustment) a bevel of the same parameters. Attention! This only applies to the repeated production of tubes of the same dimensions.

Internal counterboring / calibration

Use a knife for 15° internal recess.
(Or a custom tool).

- Install the internal recess cutting tool into any tool holder (pos. M Fig. 3.1.1.).
- Switch on the machine and use the speed control (position D Fig. 5.2.1.) to select the appropriate speed for the material to be machined. It always depends on the operator's feeling and other circumstances (material strength, cutting tool condition, etc.).
- Turn the cutting control rosette (pos. B Fig. 3.1.1.) to move the cutting tool to the edge to be cut.
- If the inside of the tube is not ideally symmetrical, the cutting tool will only touch the edge of the tube in some places. By successive machining, you then achieve a situation in which the cutting tool works around the entire circumference of the pipe edge. Continue in this way until the complete edge of the tube is machined.

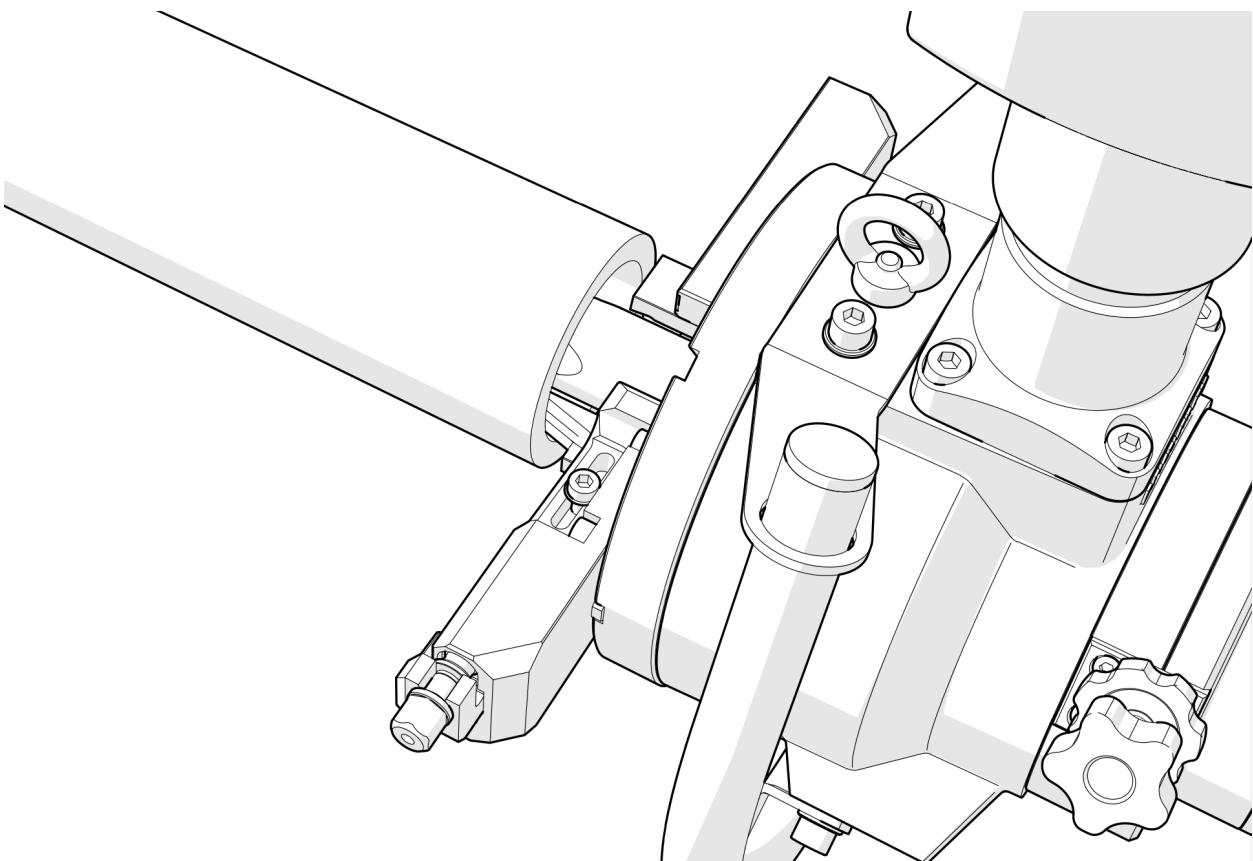

The internal countersinking/calibration is usually used in combination with the face alignment and chamfering operations mentioned above. For this reason, clamping in the 3rd cutting tool holder is assumed. However, this is not a requirement.

To adjust the cutting tools in order to perform all three operations (face alignment, beveling, and internal countersinking) at once, proceed as described in *Creating a Bevel*. Then install the internal recessing tool as the last step.

Cooling of cutting tools

We strongly recommend cooling/lubricating cutting tools during machining. This prevents overloading of the machine, increases the quality of the machined surface and considerably prolongs the life of the cutting tools. For cooling or lubrication, we recommend the use of conventional chip-machining coolants, or cutting oils in spray or applied by other means.

Bearing centring bolt

The Stinger 300 is equipped with a screw for centering the spindle bearing (pos. F fig. 3.1.1.). This element helps to eliminate any vibrations arising when machining large bevels on large diameter tubes. When vibration occurs, loosen the counter nut of the bolt and turn the bolt clockwise as required and as the situation requires. Secure the set position with the counter nut.



Important:

The Stinger 300 is equipped with a mechanical overload clutch and a thermal overload fuse. If these fuses are activated the machine is likely to overload. In these cases, the load on the machine must be reduced accordingly. The reason for the overload may be:

- **unsharp or damaged cutting tools**
- **too high strength of the material to be machined**
- **too much pressure on the cut**
- **too large pipe wall thickness**
- **inappropriate speed setting of the machine or mechanical gearbox. Incorrect setting of these parameters can lead to damage to the machine.**

6. MEMBERSHIP

Cutting tools

For the Stinger, cutting tools are available in HSS or with replaceable inserts.

	Beveling	Forehead alignment	Inner recess	Notes
HSS	30°, 37.5°	0°	15°	HSS blades can be easily adapted to other bevel shapes and angles by yourself. For example, the J bevel
VBD (HM)	30°, 37.5°	0°	-	

Contact your supplier for further information or consult the catalogue or manufacturer's website.

Stand

A stand for stationary use can be purchased for the Stinger 300 (pos. H fig. 3.1.1.). The stand is mainly used for machining shorter tubes, see fig. 6.1.

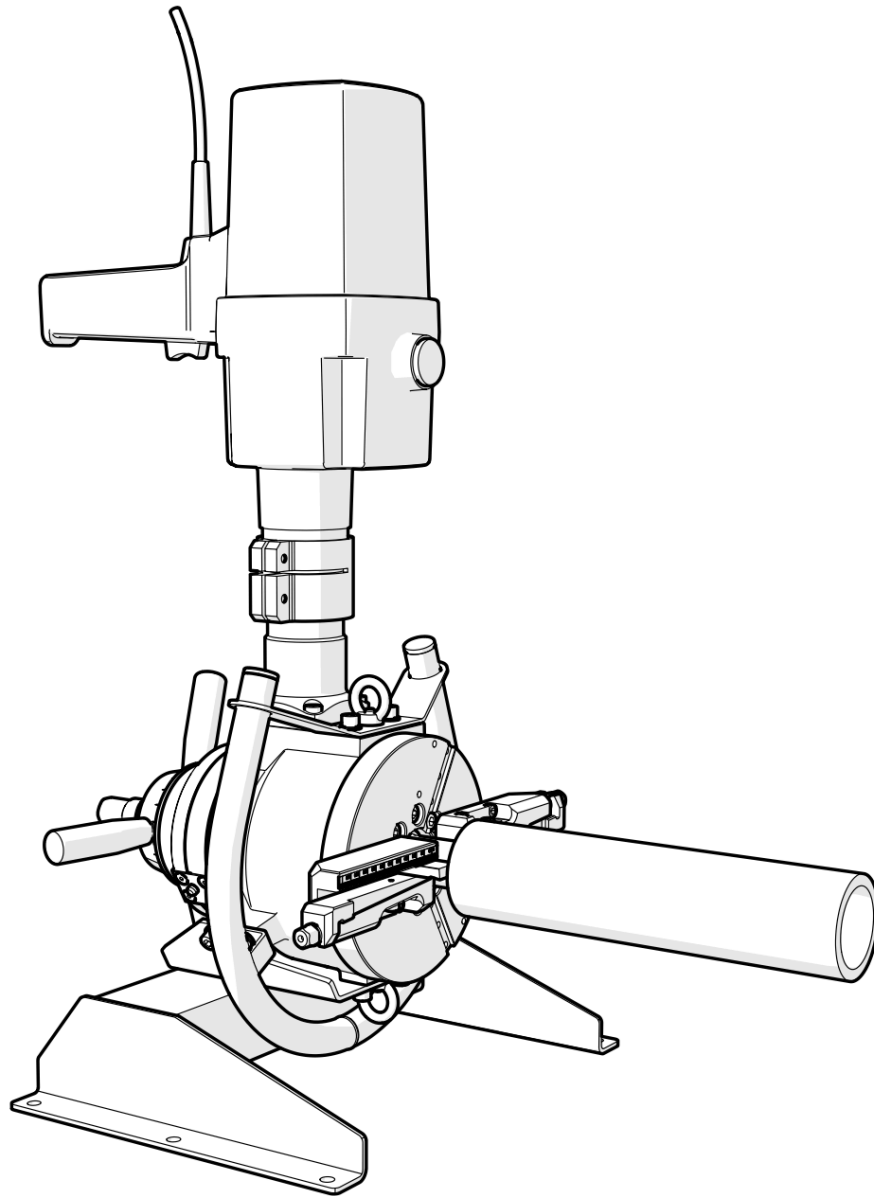

7. MAINTENANCE

7.1 Recommendations

Important:
Maintenance personnel must be qualified technicians.

Never work on moving parts of the machine, even with tools or other objects.
It is strictly forbidden to remove, modify or tamper with safety devices on the machine. In the event of such action, the manufacturer declines all responsibility for the safety of the machine.

Always use only original spare parts (see chapter 8. "Spare parts").

 **Attention:**

Always wear work gloves when carrying out maintenance on the machine. Only carry out maintenance operations on a machine that is switched off and disconnected from the power supply.

Clean the clamping mandrel, the cutting tool holder mechanism and the compensating jaws with compressed air after and before each working shift and then as necessary during the shift.

 **Attention:**

Wear safety goggles when using compressed air for cleaning purposes and never use pressures exceeding 2 bar.

Use the operator's tool supplied with the machine for adjustment and maintenance operations.

7.2. Lubrication

To ensure proper operation, the cutting tool holder mechanism and the arbor clamping mechanism must be lubricated regularly. Use a suitable lubricant and preservative spray for lubrication. Lubrication and preservation must be carried out at least once a week.

8. TECHNICAL DIAGRAMS

8.1 Electrical wiring diagram

 **Caution: When operating the machine in areas with special and hazardous influences of AD or more, increased protection of the machine against electric shock must be implemented!**

In the event of a fault, the electricity must be switched off immediately.

Work on the electrical equipment of the machine may only be carried out by an electrical expert or by persons under the supervision of such expert to ensure that the work is carried out in accordance with the applicable regulations.

 **Attention:**

None of the parts on which maintenance and repairs are carried out must be live. These disconnected parts must be checked with a two-pole measuring device that they are not live, then ground these parts and isolate the live parts!

Ensure that the voltage is switched off by disconnecting the machine from the power supply.

9. REPLACEMENT PARTS

9.1 How to order spare parts

Spare parts orders must include the following information:

- type of machine;
- serial number;
- description of the required part and part number
- quantity.

9.2 Parts most subject to wear:

- cutting tool (can be ground)
- Compensating jaws

9.3 Spare parts overview

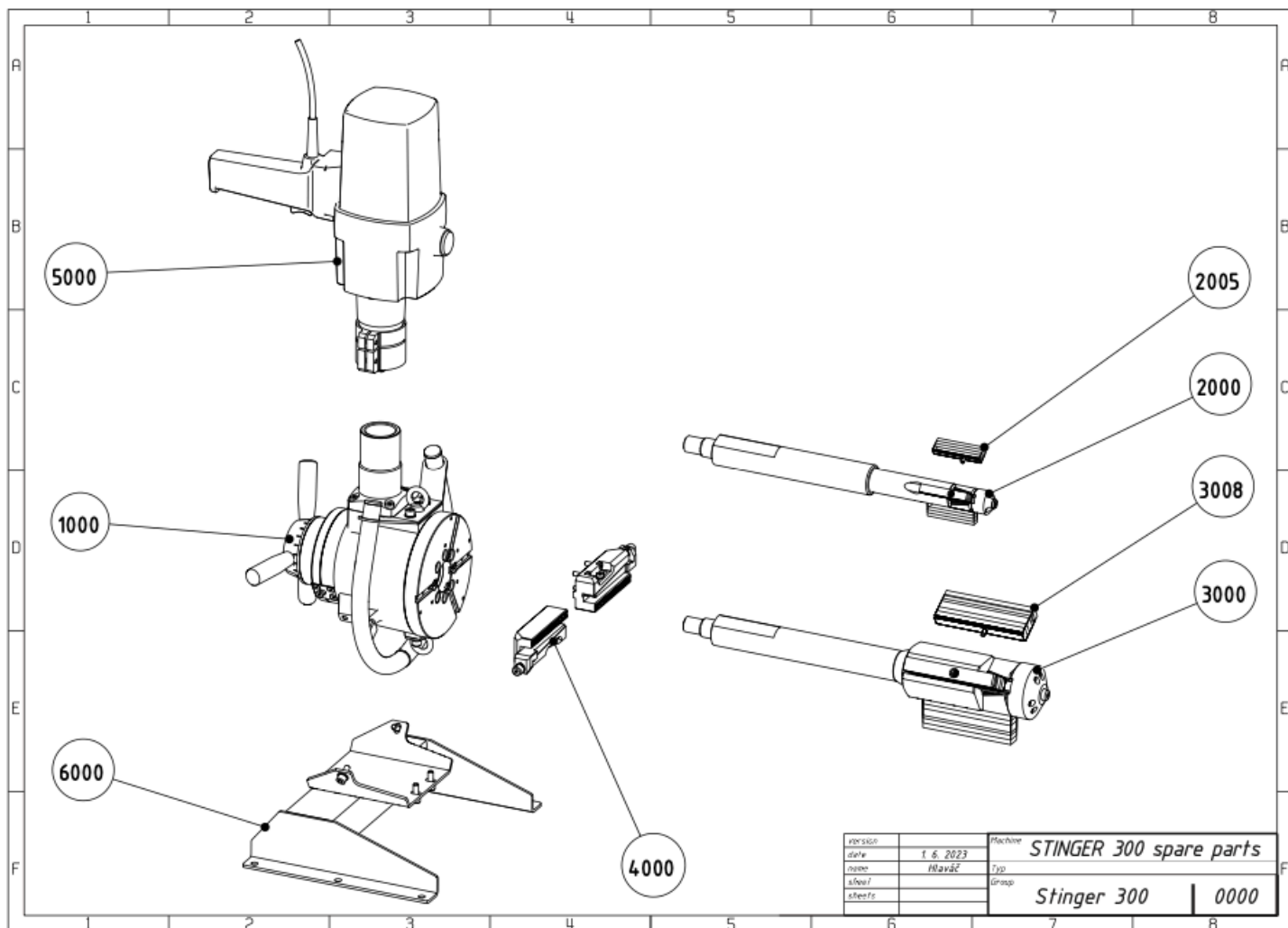

STINGER 300 SPARE PARTS

drawing no. 0000 Stinger 300

Number	Fig	Part name	Note	Pcs
30002.1000	1000	gearbox		1
30002.2000	2000	mandrel A		1
30002.2005	2005	mandrel A jaw set		3
30002.3000	3000	mandrel B		1
30002.3008	3008	mandrel B jaw set		3
30002.4000	4000	tool holder		2
30002.5000	5000	drive		1
30002.6000	6000	stand		1

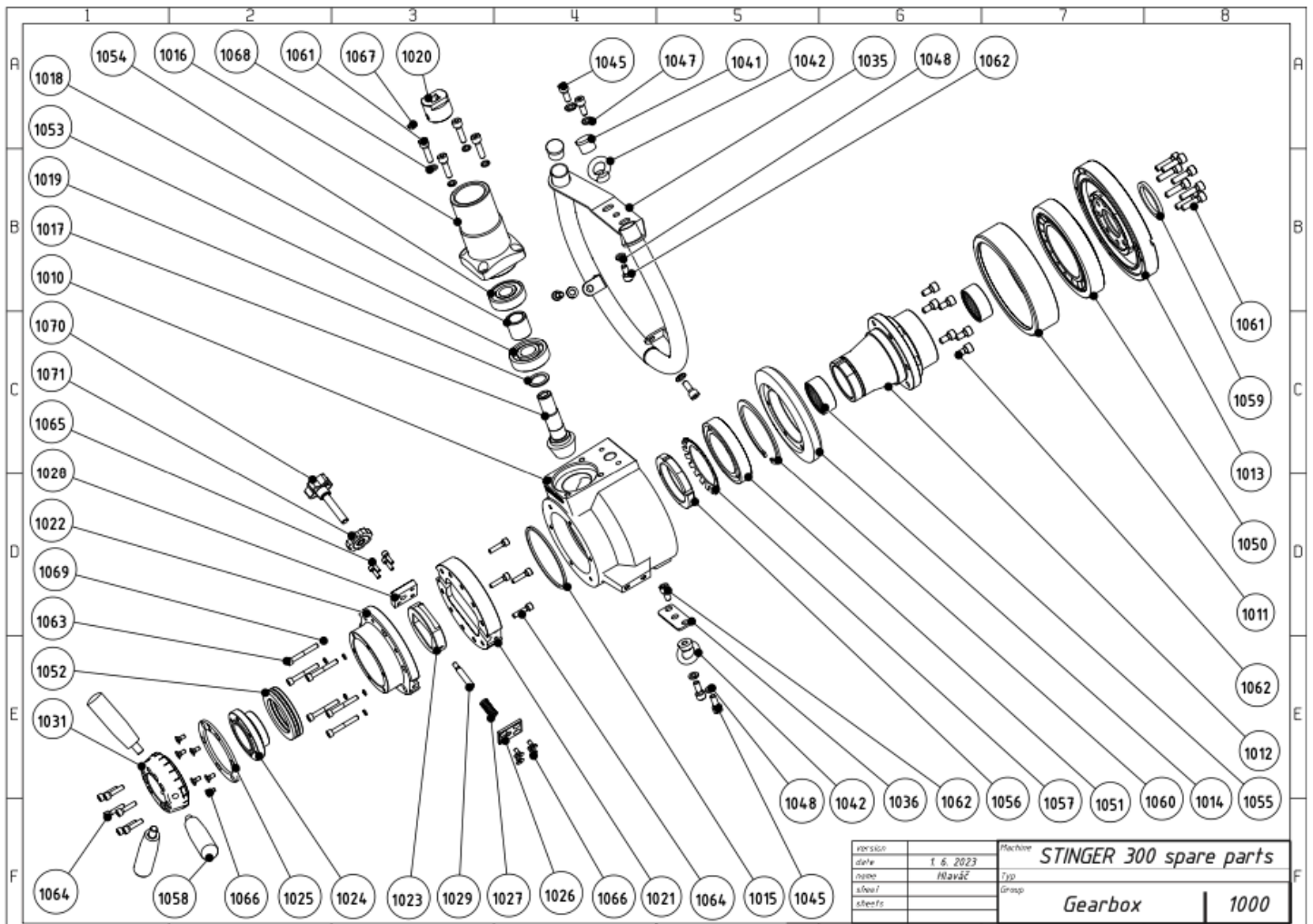

STINGER 300 SPARE PARTS

drawing no. 1000 Gearbox

Number	Fig	Part name	Pcs	Number	Fig	Part name	Pcs
30002.1010	1010	gearbox case	1	30002.1052	1052	bearing	1
30002.1011	1011	bearing ring	1	30002.1053	1053	bearing	1
30002.1012	1012	shaft	1	30002.1054	1054	bearing	1
30002.1013	1013	flange	1	30002.1055	1055	bearing	2
30002.1014	1014	toothed ring	1	30002.1056	1056	nut	1
30002.1015	1015	support ring	1	30002.1057	1057	washer	1
30002.1016	1016	piston case	1	30002.1058	1058	handle	3
30002.1017	1017	piston	1	30002.1059	1059	felt ring	1
30002.1018	1018	distance ring	1	30002.1060	1060	lock ring	1
30002.1019	1019	washer	1	30002.1061	1061	screw	12
30002.1020	1020	reduction	1	30002.1062	1062	screw	8
30002.1021	1021	lock ring	1	30002.1063	1063	screw	6
30002.1022	1022	nut cover	1	30002.1064	1064	screw	10
30002.1023	1023	stone	1	30002.1065	1065	screw	4
30002.1024	1024	nut	1	30002.1066	1066	screw	10
30002.1025	1025	ring	1	30002.1067	1067	screw	1
30002.1026	1026	spring cover	1	30002.1068	1068	washer	4
30002.1027	1027	spring	1	30002.1069	1069	washer	6
30002.1028	1028	clamping screw plate	1	30002.1070	1070	hand wheel	1
30002.1029	1029	bumping bolt	1	30002.1071	1071	nut	1
30002.1031	1031	feed ring	1				
30002.1035	1035	handle	1				
30002.1036	1036	bottom hinge plate	1				
30002.1041	1041	plug	2				
30002.1042	1042	hanging eye	2				
30002.1045	1045	screw	6				
30002.1047	1047	washer	4				
30002.1048	1048	washer	1				
30002.1050	1050	bearing	1				
30002.1051	1051	bearing	1				

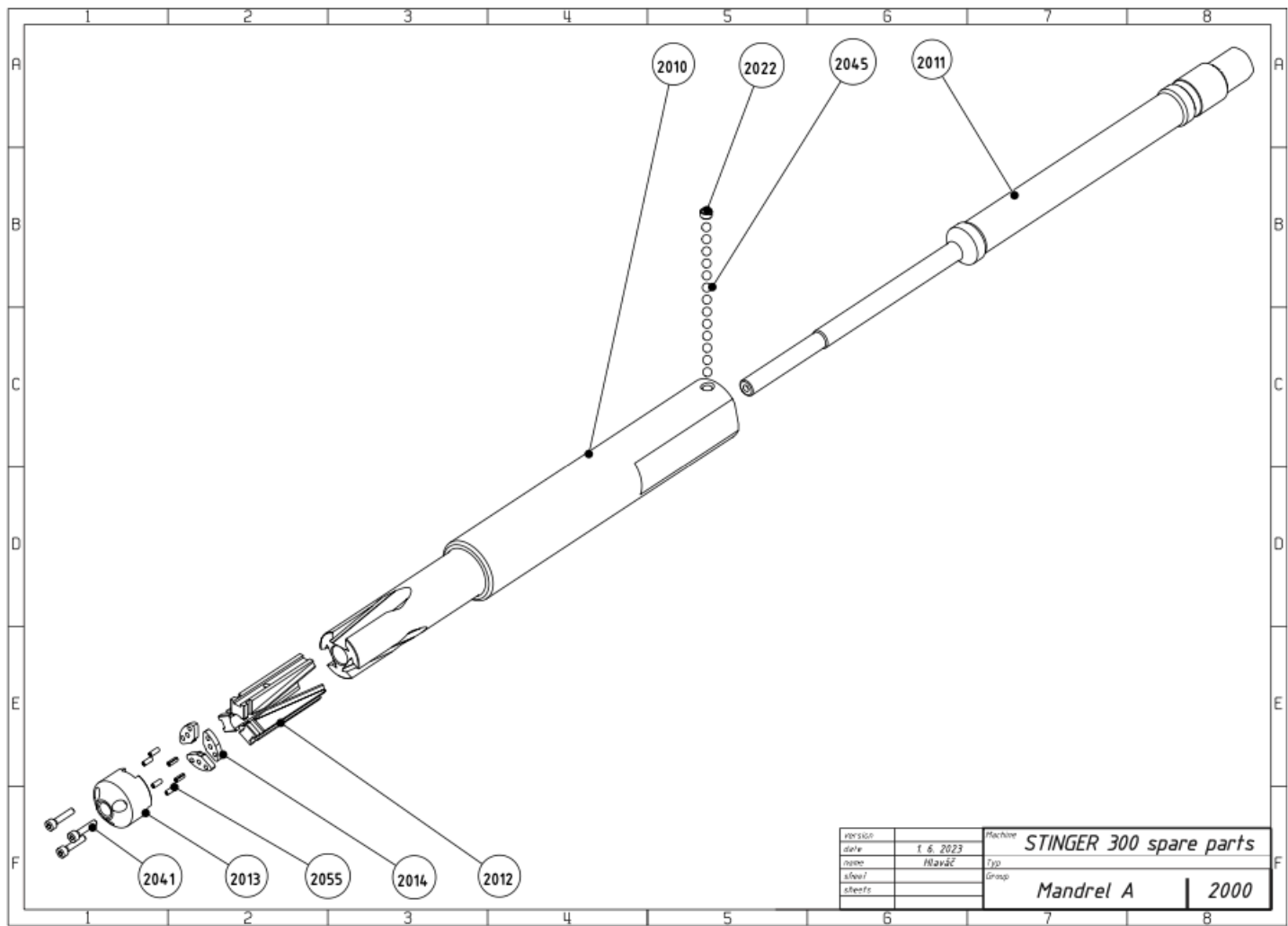

STINGER 300 SPARE PARTS

drawing no. 2000 Mandrel A

Number	Fig	Part name	Note	Pcs
30002.2010	2010	mandrel-A axis		1
30002.2011	2011	mandrel-A screw		1
30002.2012	2012	mandrel-A wedge		3
30002.2013	2013	mandrel-A head		1
30002.2014	2014	mandrel-A board		3
30002.2022	2022	thread plug		1
30002.2041	2041	screw		3
30002.2045	2045	bearing ball		13
30002.2055	2055	flexible pin		6

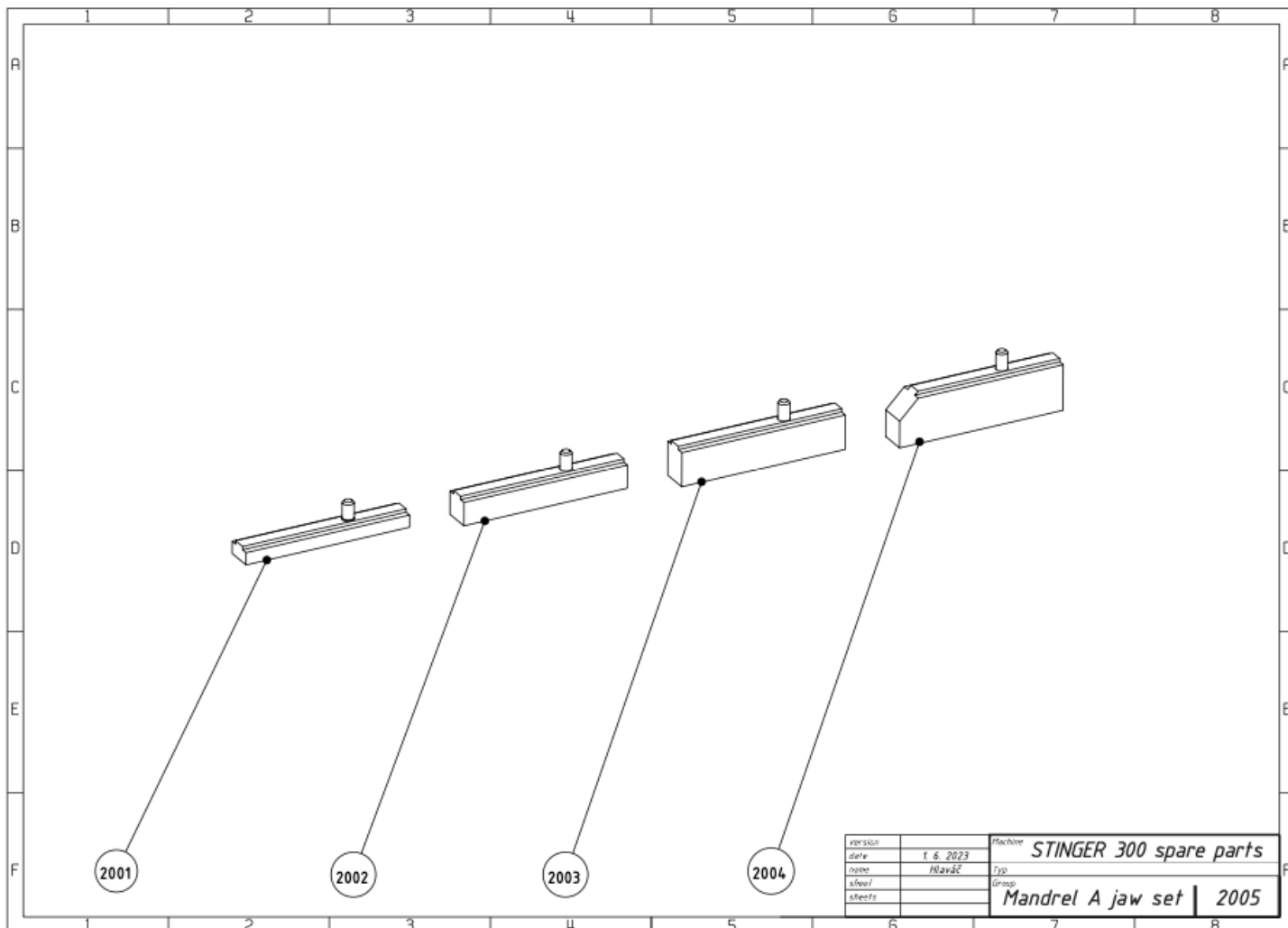

STINGER 300 SPARE PARTS

drawing no. **2005 Mandrel A jaw set**

Number	Fig	Part name	Note	Pcs
30002.2001	2001	jaw assembly A-1		1
30002.2002	2002	jaw assembly A-2		1
30002.2003	2003	jaw assembly A-3		1
30002.2004	2004	jaw assembly A-4		1

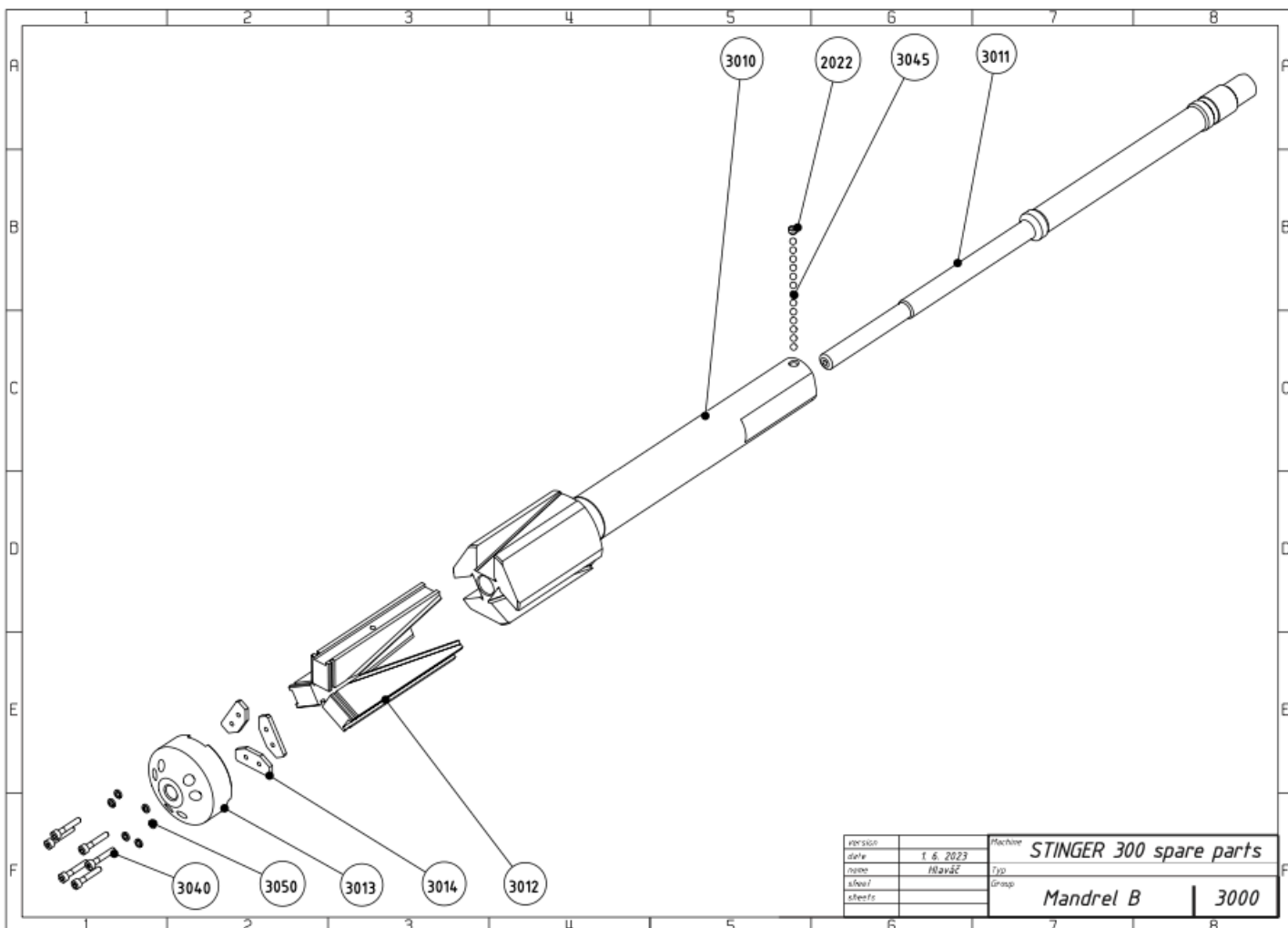

STINGER 300 SPARE PARTS

drawing no. 3000 Mandrel B

Number	Fig	Part name	Note	Pcs
30002.3010	3010	mandrel-B axis		1
30002.3011	3011	mandrel-B screw		1
30002.3012	3012	mandrel-B wedge		3
30002.3013	3013	mandrel-B head		1
30002.3014	3014	mandrel-B board		3
30002.2022	2022	thread plug		1
30002.3040	3040	screw		6
30002.3045	3045	bearing ball		13
30002.3050	3050	washer		6

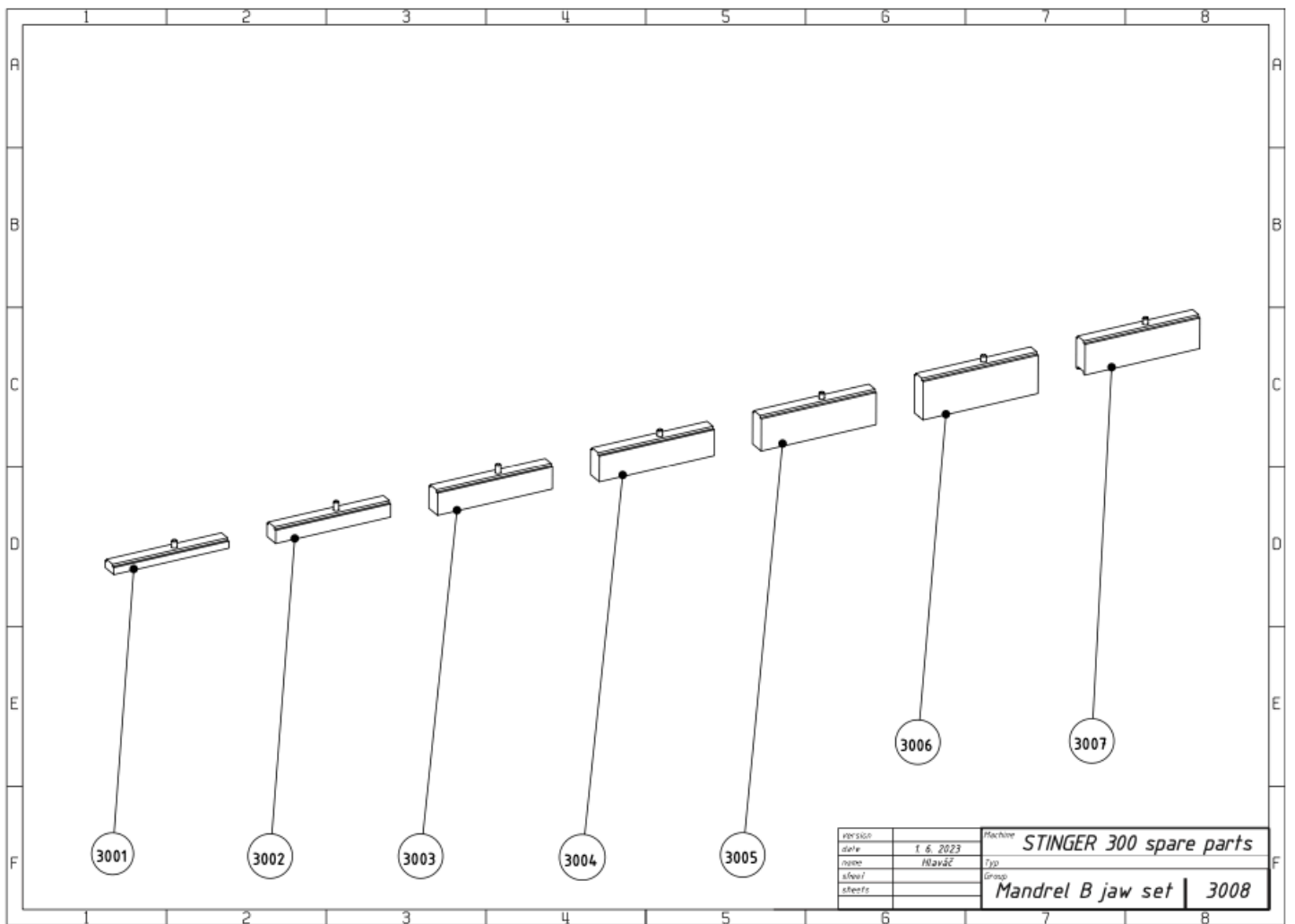

STINGER 300 SPARE PARTS

drawing no. 3008 Mandrel B jaw set

Number	Fig	Part name	Note	Pcs
30002.3001	3001	jaw assembly B-1		1
30002.3002	3002	jaw assembly B-2		1
30002.3003	3003	jaw assembly B-3		1
30002.3004	3004	jaw assembly B-4		1
30002.3005	3005	jaw assembly B-5		1
30002.3006	3006	jaw assembly B-6		1
30002.3007	3007	BOOSTER jaws assembly		1

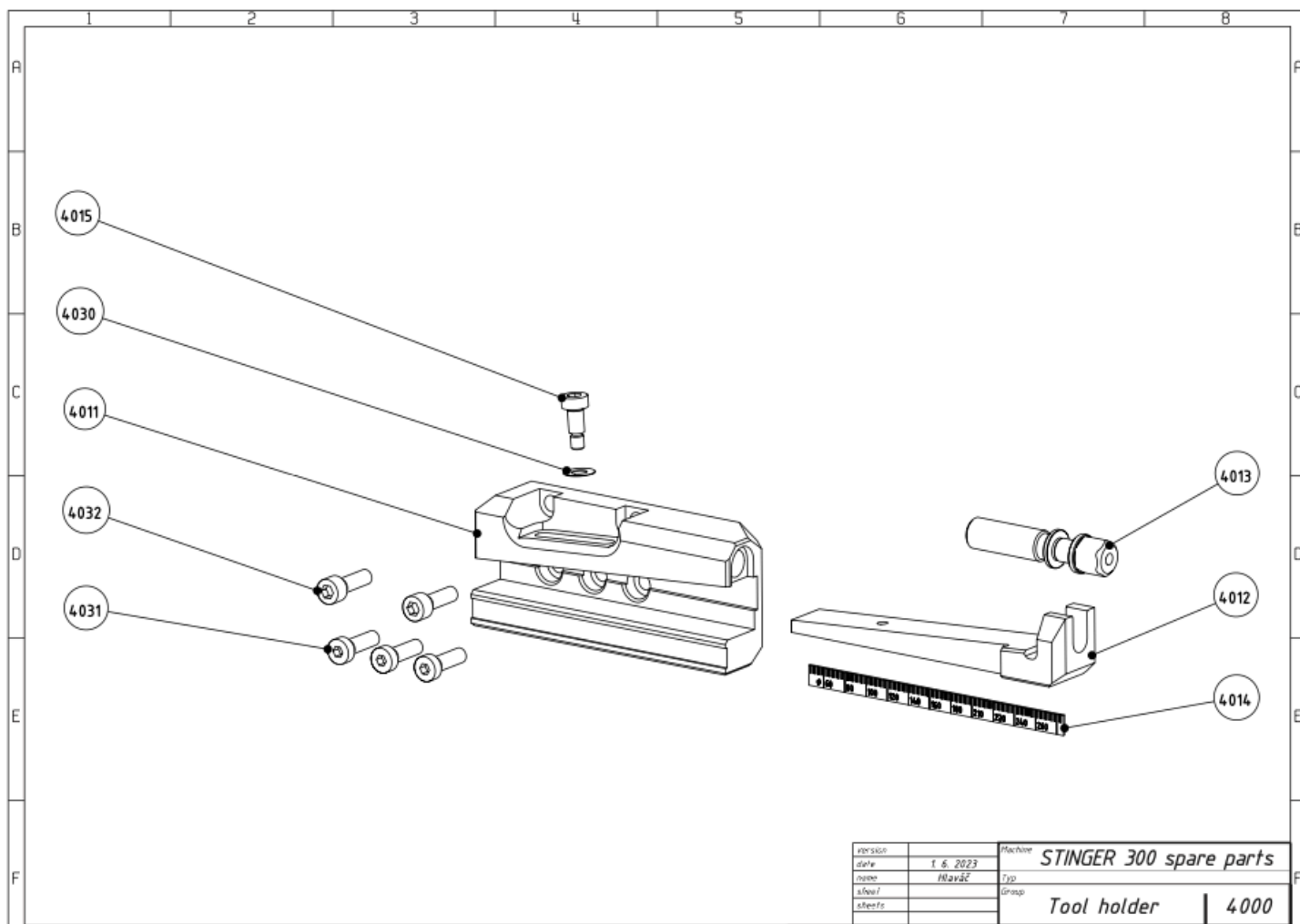

version		Machine	STINGER 300 spare parts	
date	1.6.2023	Typ		
name	Pravák	Group	Tool holder	4000
sheet				
sheets				

STINGER 300 SPARE PARTS

drawing no. 4000 Tool holder

Number	Fig	Part name	Note	Pcs
30002.4011	4011	body		1
30002.4012	4012	wedge		1
30002.4013	4013	screw		1
30002.4014	4014	ruler		1
30002.4015	4015	special screw		1
30002.4030	4030	distance washer		1
30002.4031	4031	screw		3
30002.4032	4032	screw		2

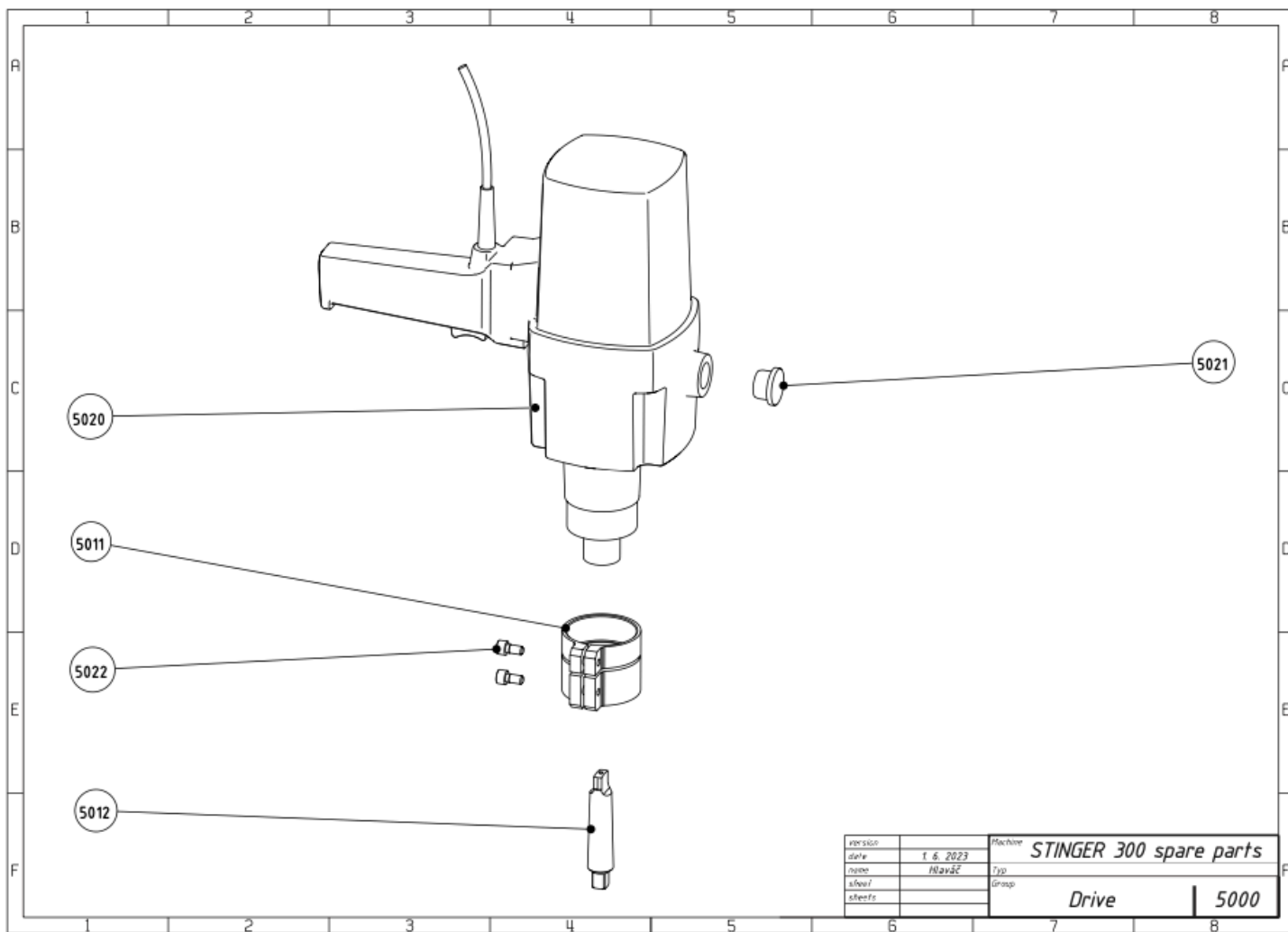

STINGER 300 SPARE PARTS

drawing no. 5000 Drive

Number	Fig	Part name	Note	Pcs
30002.5011	5011	clutch		1
30002.5012	5012	mandrel		1
30002.5020	5020	drive		1
30002.5021	5021	plug		1
30002.5022	5022	screw		2

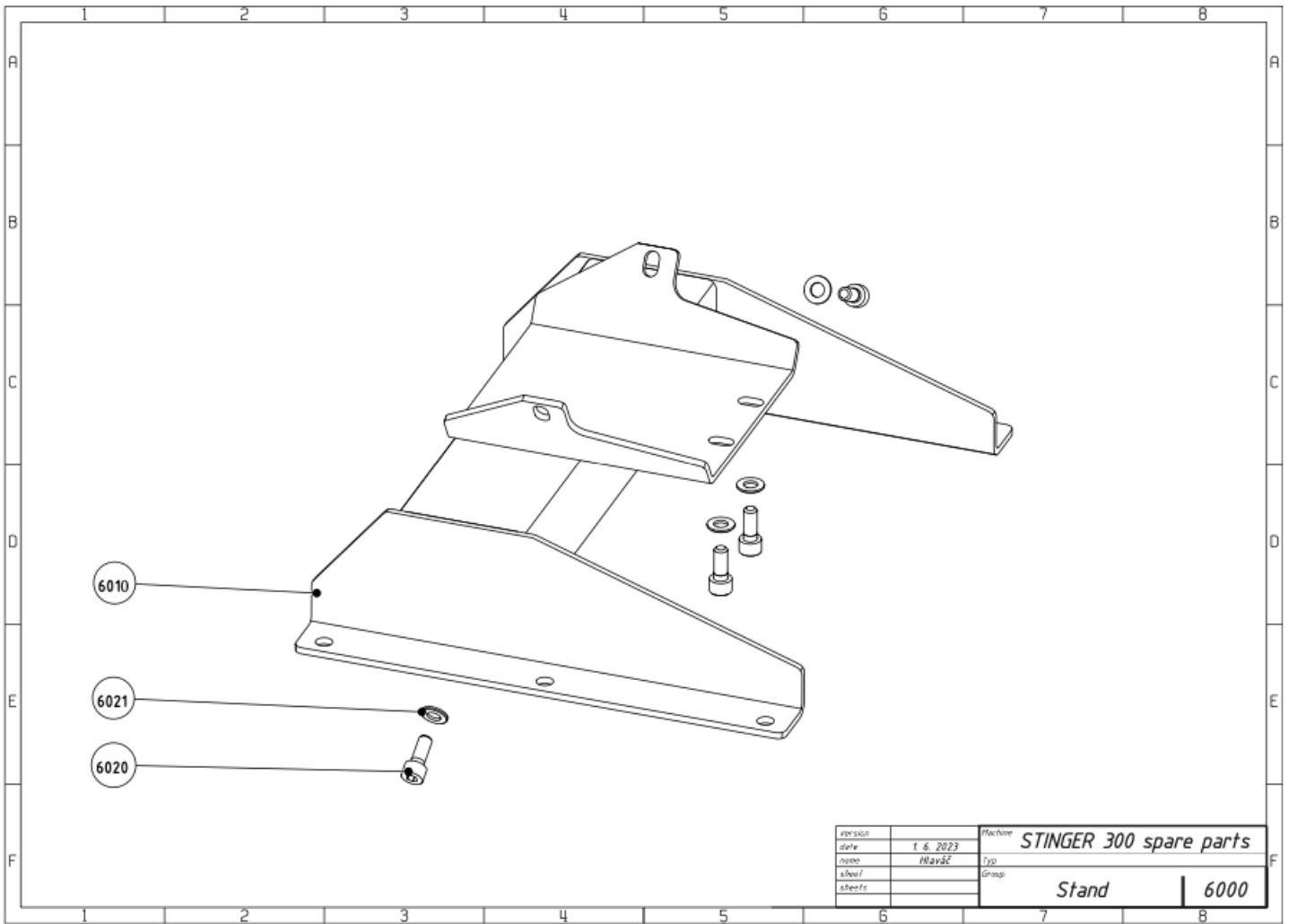

STINGER 300 SPARE PARTS

drawing no. 6000 Stand

Number	Fig	Part name	Note	Pcs
30002.6010	6010	body		1
30002.6020	6020	screw		4
30002.6021	6021	washer		4

A copy of this manual is supplied with every Stinger 300.

All rights reserved.

No part of this publication may be reproduced without the prior permission of N.KO

Manufacturer and distributor address:

N.KO spol. s r.o.

Taborská 398/22

293 01 Mladá Boleslav

tel: +420 326 772 001 fax: +420 326 774 279

email:nko@nko.cz

USA Distributor's Address:

BEVELER USA INC.

Business Office, Workshop, Warehouse (PA)

(a Member of Richtr Group)

511 Parkway View Dr,

Pittsburgh, PA 15205

Toll Free Number: 1-800-973-1138

Phone Ambridge (PA) office: 1-412-452-2563

email:service@bevelerusa.com